



SORAA BRILLIANT HL™

The Soraa Brilliant HL single-source COB lamp combines Soraa's world-class optics design and driver technology with a photopically efficacious LED.

SORAA POINT SOURCE OPTICS™

With a point source and sophisticated folded optics, Soraa creates very controlled beam angles from 25 to 60 degrees, in form factors as challenging as the compact GU10 resulting in smooth uniform beams and crisp shadows.

ENERGY EFFICIENCY AND LONG LIFE

85% more energy efficient than standard halogen lamps

Typical payback of one year or less

Rated lifetime to L70: 35,000hrs

Warranty: 3yrs or 25,000hrs whichever comes first

Detailed warranty information available at soraa.com/resources/legal

CERTIFICATIONS

RoHS, CE



GENERAL SPECIFICATIONS

Form Factor

Width: 49.9mm (1.96")

Height: 53.5mm (2.10")

Weight: 61g

Operating Temperature

Minimum: -40°C (ambient)

Typical: 85°C - 95°C (base)

Maximum: 100°C (base)

Electrical

Wattage: 9.5W

Power factor: 0.75

Voltage: 230V +/- 23V

Frequency: 50/60Hz

Dimming and Flicker

Dimmable to <20%

Percent Flicker: 13%

Output Range:	690 - 725 lumen
Beam Angle Range	25°, 36°, 60°
Colour Metrics	CCT: 2700K, 3000K Colour Rendering CIE Metrics: CRI 90, R9 50
Application	Not suitable for enclosed, lensed, baffled, or deeply recessed fixtures. Halogen replacement for indoor applications.



HIGHLY COMPATIBLE

Geometrically compatible with standard fixtures and suitable for damp locations.

Not suitable for enclosed, lensed, baffled, or deeply recessed fixtures. Compatible with trailing edge phase cut dimmers only. Not for use with leading edge dimmers.

Check individual lamp website pages for compatibility data. For more information visit: www.soraa.com.

INTENDED USE AND APPLICATIONS

Intended for use in GU10 compatible recessed downlights, track lighting and other indoor and outdoor applications.

Soraa lamps are designed to safely turn down in any thermal environment not conducive to minimum airflow or proper ventilation.

DIMENSIONS

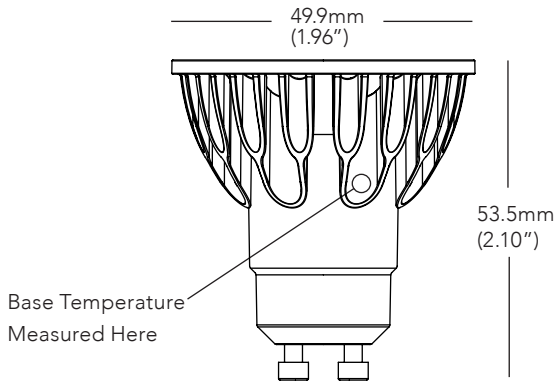

25 DEGREE BEAM

Beam Dia at 50% Intensity (m)	Field Dia at 10% Intensity (m)	Lux (% of Intensity)
0.4	0.7	100%
0.9	1.5	25%
1.3	2.2	11%
1.8	2.9	6%
2.2	3.6	4%

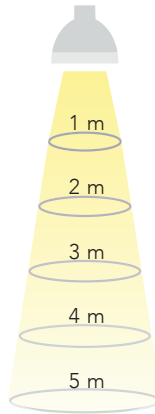

36 DEGREE BEAM

Beam Dia at 50% Intensity (m)	Field Dia at 10% Intensity (m)	Lux (% of Intensity)
0.6	1.1	100%
1.3	2.2	25%
1.9	3.3	11%
2.6	4.3	6%
3.2	5.4	4%

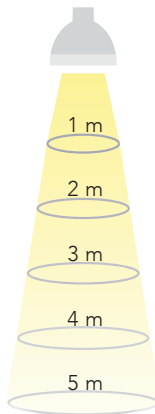

60 DEGREE BEAM

Beam Dia at 50% Intensity (m)	Field Dia at 10% Intensity (m)	Lux (% of Intensity)
1.2	1.8	100%
2.3	3.6	25%
3.5	5.4	11%
4.6	7.2	6%
5.8	9.0	4%

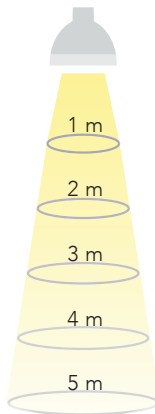

Note: Lux may be calculated by multiplying the peak Intensity of the desired model number by the percentage in the tables above

SPECIFICATIONS BY MODEL NUMBER* SORAA LED MR16-GU10 9.5W

Model #	Product Code	CCT (K)	Beam Angle	Field Angle	Peak Intensity	Total Flux (Lm)	Efficacy (Lm/W)	CRI	90° Lumens	McA	EEl
BRILLIANT HL SERIES											
SM16GW-09-25D-827-H1-S3	11299	2700	25	38	3550	690	77	90	640	3	A+
SM16GW-09-36D-827-H1-S3	11303	2700	36	54	1700	690	77	90	620	3	A+
SM16GW-09-60D-827-H1-S3	11307	2700	60	84	670	690	77	90	620	3	A+
SM16GW-09-25D-830-H1-S3	11297	3000	25	38	3730	725	81	90	695	3	A+
SM16GW-09-36D-830-H1-S3	11301	3000	36	54	1790	725	81	90	675	3	A+
SM16GW-09-60D-830-H1-S3	11305	3000	60	84	700	725	81	90	675	3	A+

CCT: Correlated Colour Temperature **McA**: White Point Accuracy in McA step **SNAP**: SORAA SNAP System Compatible **EEl**: Energy Efficiency Index

*Specifications are at stable warm operating conditions (25°C ambient)

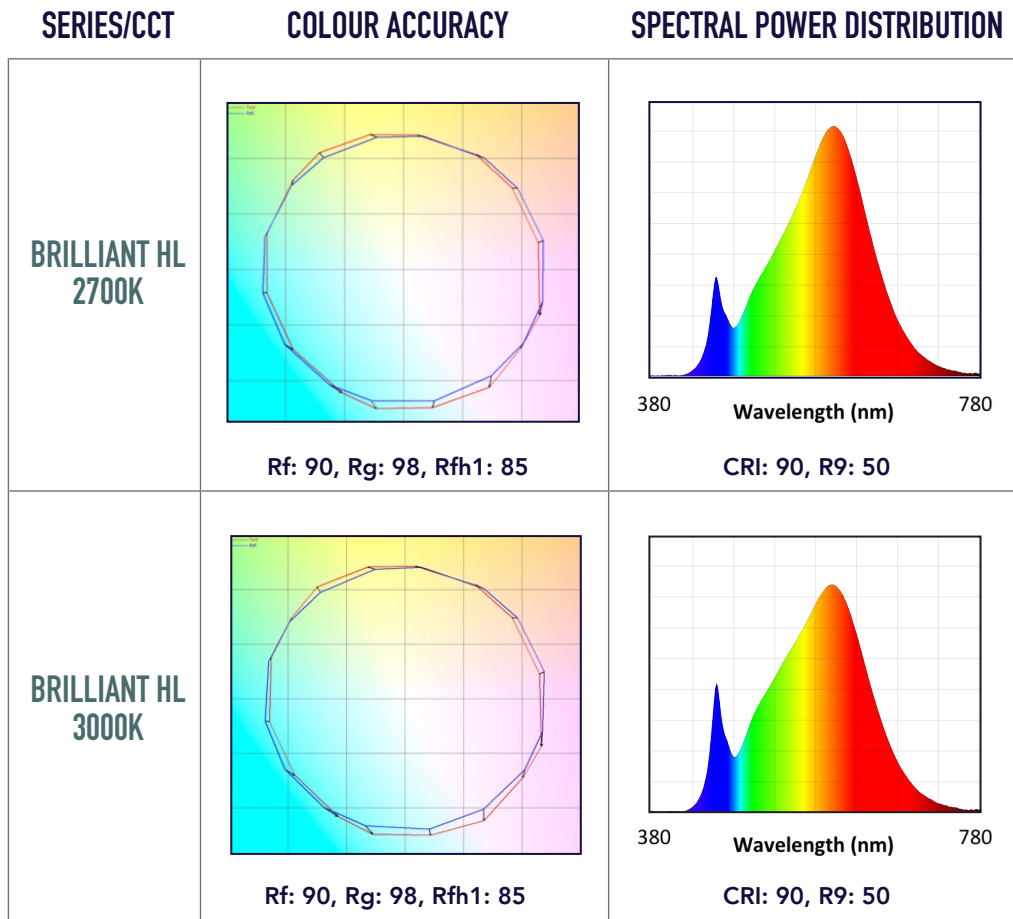

Rf: TM-30 metric measuring colour fidelity (whether colours are similar to those under natural light). Rf is a more accurate version of the CRI Ra. Rf is 100 for natural light.
 Rg: TM-30 metric measuring colour gamut (whether colours are more saturated than under natural light). Rg is 100 for natural light.
 Rfh1: TM-30 metric measuring colour fidelity for red tones. Rfh1 is a more accurate version of the CRI R9. Rfh1 is 100 for natural light.