

IMPORTANT SAFETY INSTRUCTIONS:

When installing or using the track system, basic safety precautions should always be followed, including the following:

1. Read all instructions before attempting to install the item.

2. Make certain power is turned off on the main electrical panel before starting installation or attempting any maintenance.

3. Do not install this lighting system in a damp or wet location.

4. Ensure the appropriate track connector is matched up with its compatible track system.

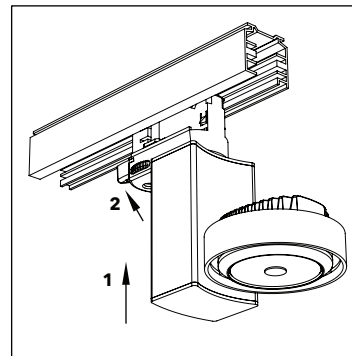
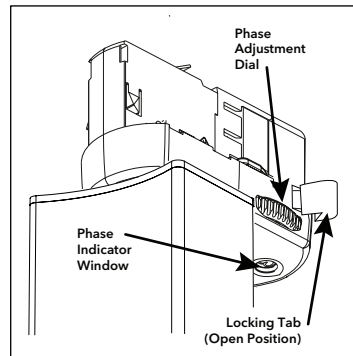
**Installation Instructions****G - Global Adaptor (3 circuit), GS - Stucchi 9009, GC - Nordic GAC69, EUGD - EUTRAC 99-759 + 99-698 (3 circuit + Data)**

Choose the phase (1, 2, or 3) with the phase adjustment dial before installing fixture in track. Phase number is visible in phase indicator window on bottom of track adaptor. Note location of locking tab in open position.

Step 1. Place the fixture into track groove and make sure that the side with the locking clip is opposite the polarity groove on the track. Push fixture up into track.

Step 2. Push locking tab counter clockwise to lock.

Step 3. Once installation is complete, turn on power to confirm fixture is working properly.

Step 4. To remove the fixture, pull the locking tab clockwise to unlock, then pull fixture down to remove.

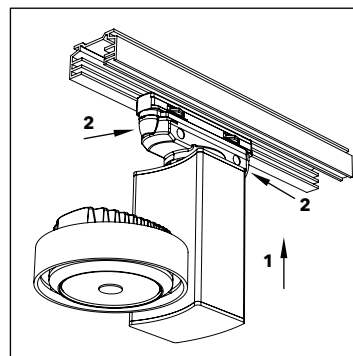
**G1 Global Adaptor (1 circuit)**

Step 1. Place the fixture into track groove and make sure that the side with the locking clip is opposite the polarity groove on the track. Push fixture up into track.

Step 2. Push locking tabs on ends of adaptor to lock.

Step 3. Once installation is complete, turn on power to confirm fixture is working properly.

Step 4. To remove the fixture, pull the locking tab clockwise to unlock, then pull fixture down to remove.

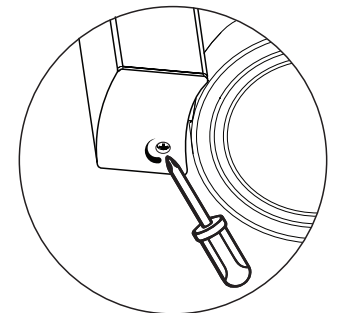
**Luminaire Level Dimming**

For ART luminaires with adjustable dimming, locate dimming button on bottom of luminaire as show above. Using a Phillips screwdriver, adjust light level as required.