

3.5" (90mm) Recessed Downlights (50mm lens) Installation Instructions

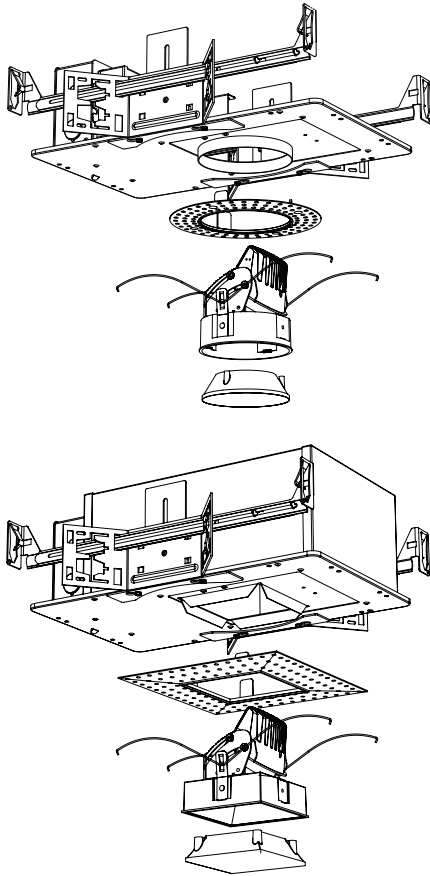

Light Engines (Trimmed & Trimless)		Driver		Frames		Trims	
DESA	LE Square Adjustable	DD50	Downlight Driver Kit	DFR-IC	Round IC	DTSA	Square Adjustable
DERA	LE Round Adjustable			DFS-IC	Square IC	DTSW	Square WallWash
DESF	LE Square Fixed			DFR-T	Round Non-IC	DTSF	Square To Round Fixed
DERF	LE Round Fixed			DFS-T	Square Non-IC	DTRA	Round Adjustable
DESW	LE Square Wall Wash			DRD	Remodler	DTRF	Round Fixed
DERW	LE Round Wall Wash					DTRW	Round Wall Wash

Read and understand these instructions before installing luminaire (fixture).

This luminaire is intended for installation in accordance with the National Electrical Code and local regulations. To assure full compliance with local codes and regulations, check with your local electrical inspector before installation. To prevent electrical shock, turn off electricity at fuse box before proceeding. Allow fixture to cool before handling.

The following warning applies to non-IC configurations only:
Caution (RISK OF FIRE) Do not install insulation above or within 3 inches (76mm) of any part of luminaire. Use only with LED light engines and reflector trims provided by Soraa. Use of other manufacturers trims may void the Underwriters Laboratories listing and could constitute a fire hazard.

SUITABLE FOR WET LOCATIONS WITH WET LOCATION TRIM. COVERED CEILING MOUNT ONLY.

IC and Non-IC Frame Ceiling Grid Installation

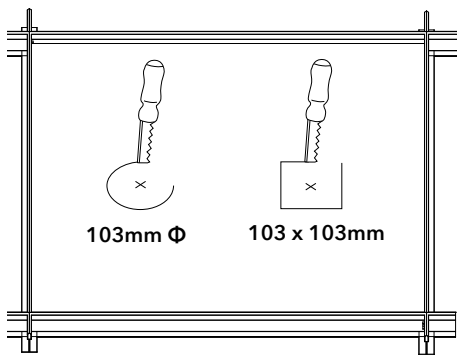

Figure A

Step 1
Preparation: Cut hole in ceiling tile (by others) at 103mm on center for round and 103 x 103mm for square at the position desired and place ceiling tile in grid (by others) (Fig. A).

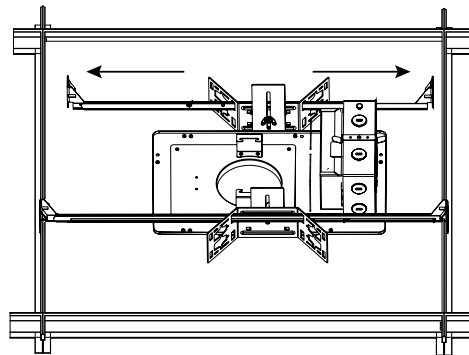

Figure B

Step 2
Position Frame: Place frame on top of ceiling tile and center the frame aperture on the ceiling tile hole cut in Step 1. Orient the frame to align with the grid. Extend the end brackets and hook onto top of ceiling grid (Figs. B and C). Grid brackets can also attach to ends of frame as shown on Page 2 in Figures D and E.

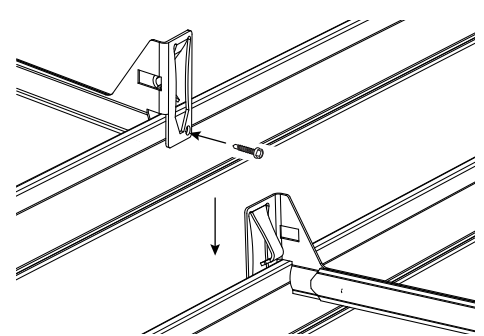

Figure C

Step 3
Tie to Grid and Lock Frame: Loosen adjustment wing nuts on frame to raise frame above ceiling tile, then tighten. Check frame to ensure that it is still centered on the ceiling tile, and adjust accordingly. When the frame is positioned satisfactorily, attach frame to ceiling grid with self-tapping sheet metal screws (Fig. C). Loosen frame adjustment wing nuts, lower frame to sit flush with ceiling tile, then tighten wing nuts.

3.5" (90mm) Recessed Downlights (50mm lens) Installation Instructions

Alternate Ceiling Grid Mounting

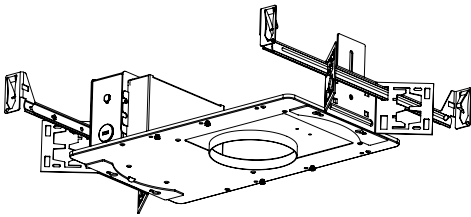

Figure D

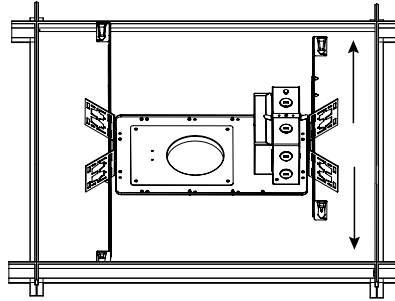

Figure E

Step 1

For alternate ceiling grid mounting, attach grid brackets to ends of frame as shown in Figure D.

Step 2

Place frame on top of ceiling tile and center the frame aperture on the ceiling tile hole. Orient the frame to align with the grid. Extend the end brackets and hook onto top of ceiling grid (Figure E). Grid brackets have breakaway sections to enable custom fitting to tight grid spaces.

Wood frame ceiling mounting

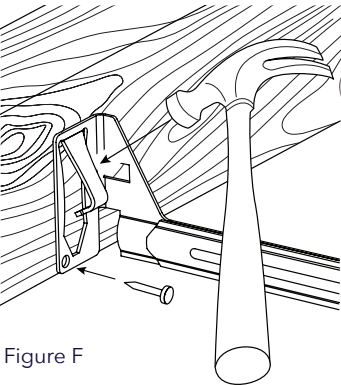

Figure F

Step 1

Loosen wing nuts on frame clamps enough to allow free vertical movement of frame on extendable mounting arms.

Step 2

Position and install frame: Extend frame arms and position frame between joists with the end bracket at one end placed against, and flush to, the bottom of the joist. When positioned, anchor end bracket by hammering gripper cleat in bracket into wood as show in Fig. D, then nail or screw bracket to joist using provided hole in the bracket (Fig. D).

Extend the end bracket at the opposite end of the frame until it contacts the opposite joist. Align and attach. Slide the frame along the mounting bars until the aperture is in the desired position and lock the frame in place by tightening the wing nuts on the mounting bar clamps.

Metal furring/hat channel ceiling mounting

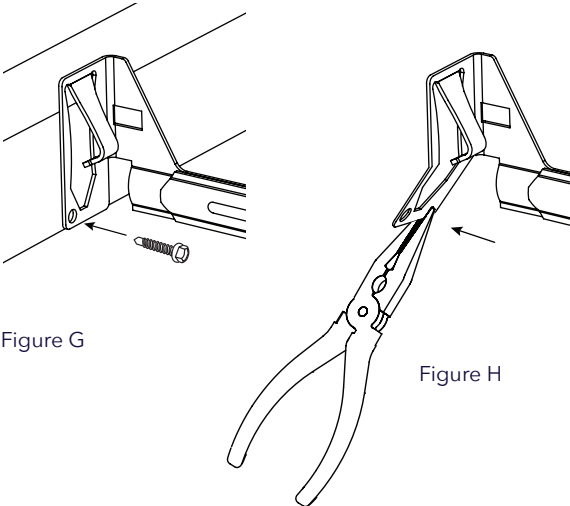

Figure G

Figure H

Step 1

Loosen wing nuts on frame clamps enough to allow free vertical movement of frame on extendable mounting arms.

Step 2

Adjust end bracket: End brackets can be modified to fit different metal furring strips or hat channel shapes by bending as shown in Fig. F.

Step 3

Position and install frame: Extend frame arms and position frame between furring strips with the end bracket at one end placed against, and flush to, the bottom of the furring strip, or as needed on hat channel. When positioned, screw bracket to furring strip or hat channel with self-tapping sheet metal screw using provided hole in the bracket (Fig. E).

Extend the end bracket at the opposite end of the frame until it contacts the opposite furring strip or hat channel. Align and attach. Slide the frame along the mounting bars until the frame aperture is in the desired position and lock the frame in place by tightening the wing nuts on the mounting bar clamps.

Instructions for all applications

Wire in: Wire to supply leads. Wire neutral lead supply lead to white wire, hot supply lead to black wire, and bare copper and/or green wire must be connected to supply ground. Place all electrical connections in the j-box and close j-box door.

For luminaires with 0-10V dimming, or digital dimming: wire purple & gray leads to appropriate control wires.

3.5" (90mm) Recessed Downlights (50mm lens) Installation Instructions

In Frame Light Engine Installation

Figure A

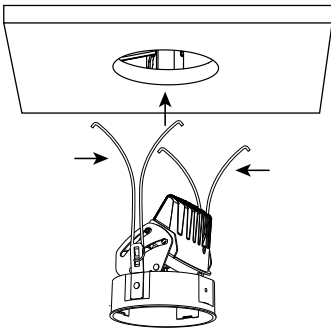

Step 1

Squeeze tension springs together in order to push the light engine into the ceiling (Fig. A).

Figure B

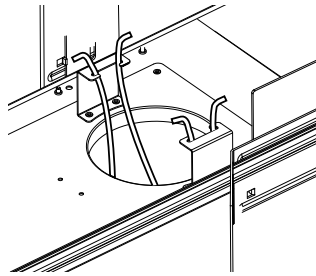

Step 2

Insert tension springs in notched tabs inside frame as shown in Fig. B.

Figure C

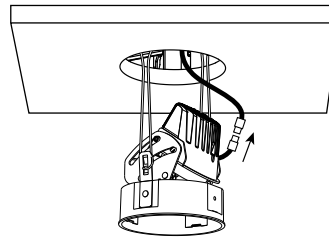

Step 3

Allowing luminaire to hang from tension springs, connect to power supply with quick connector (Fig C).

Figure D

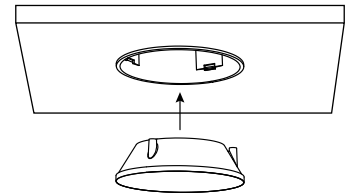

Step 4

Snap light engine into frame and install trim (Fig. D).

Note: for wallwash trim installation, ensure proper orientation towards wall before installing light engine.

Trimless Adaptor Installation- Use with Trimless Light Engine Only

Figure A1

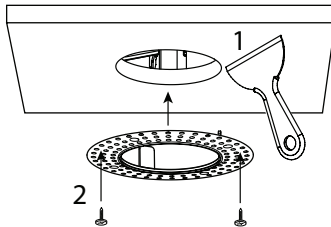
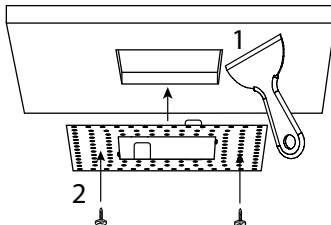

Figure A2



Step 1

Insert trimless adapter into ceiling opening. For maximum adhesion a bead of plaster/compound can be applied to the ceiling before placing the trimless trim ring into position. Fasten to ceiling with screws (Figs. A1 & A2).

Step 2

Place plastic plaster shield in trimless adapter until surface is flush (Figs. B1 & B2).

Figure B1

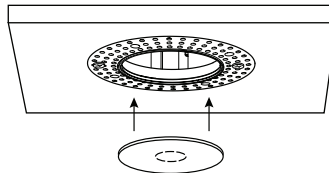
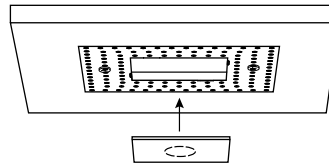

Figure B2



Step 3

Starting at the outside edge, apply plaster/compound to trimless trim adapter. (Figs. C1 & C2). Continue to apply plaster/compound until lip of trimless trim adapter is covered. Allow plaster/compound to dry.

Step 4

Feather, sand and fill as necessary to achieve required finish. Make sure to sand until trimless trim adapter lip is exposed.

Step 5

Paint as required and allow paint to dry.

Figure C1

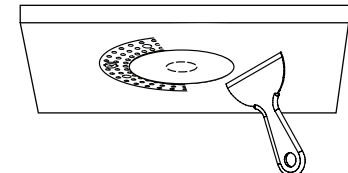
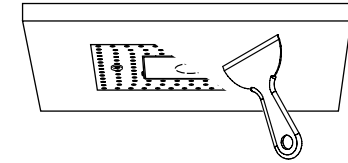

Figure C2



Step 6

Remove plastic plaster shield. If the plaster shield is covered with plaster/compound use a sharp blade to cut around inside circumference of trimless trim adapter lip before removing.

Step 7

Install Soraa light engine and trim per installation instructions. To protect ceiling surface, install light engine while holding onto the trim and keeping the trim level to the ceiling until trim contacts trim ring. Fine adjustment may be needed to fully set trim into trim ring lip.

3.5" (90mm) Recessed Downlights (50mm lens) Installation Instructions

Remodler/Frameless Installation

Figure A1

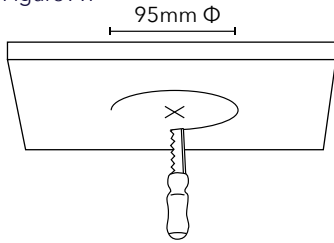

Figure B1

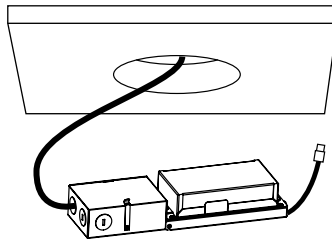

Figure C1

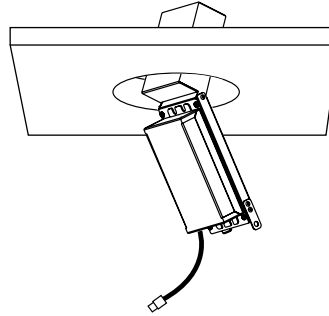

Figure D1

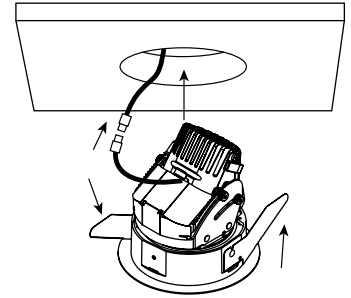

Figure A2

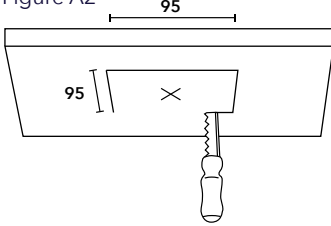

Figure B2

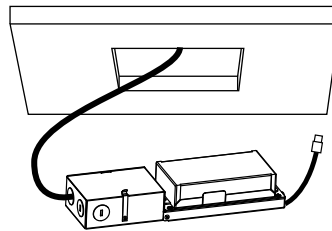

Figure C2

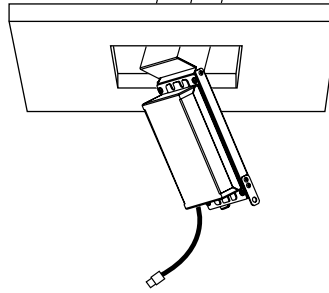
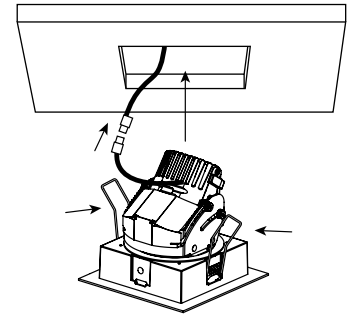

Figure D2



Step 1

Cut an opening in the ceiling at 95mm to accommodate the remodeler to be installed (Figs. A1 and A2). Ensure that there is nothing in the ceiling to obstruct the installation.

Step 2

Wire to supply leads. (Figs. B1 & B2). White wire to neutral supply lead, black wire to hot supply lead, and bare copper and/or green wire must be connected to supply ground. Place all electrical connections in the j-box and close the j-box door. For luminaires with 0-10V dimming or digital dimming, wire purple & gray leads to appropriate control wires.

Step 3

Pass the j-box/power supply bracket (Fig. C1) or stand-alone power supply (Fig. C2) through ceiling opening and secure in plenum.

Step 4

Connect luminaire to power supply, compress retainer clips, and insert luminaire in ceiling opening (Figs. D1 & D2).

Step 5

Install trim in luminaire (Figs. E1 & E2).

Figure E1

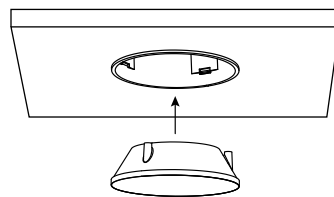
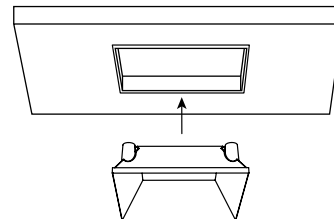

Figure E2



3.5" (90mm) Recessed Downlights (50mm lens) Installation Instructions

In Frame Installation with Remodeler Light Engine- Trimmed Light Engine Only

Figure A

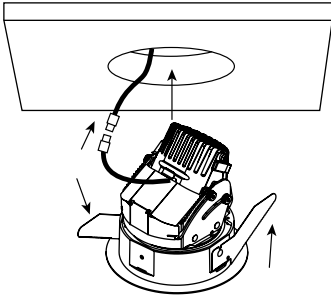

Figure B

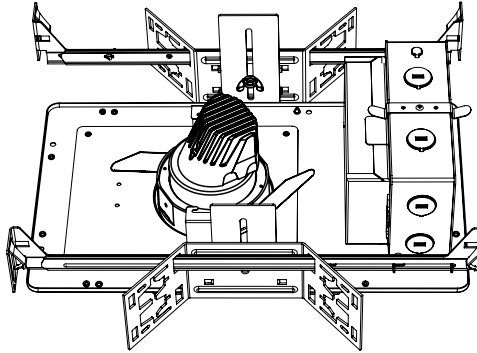

Figure C

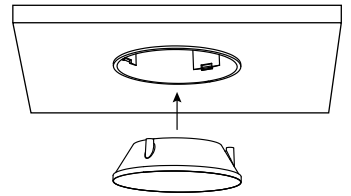

Figure A1

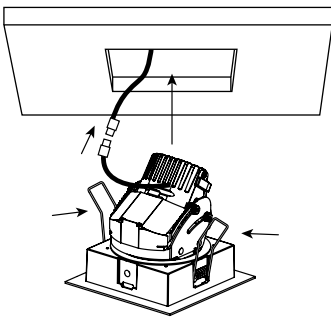

Figure B1

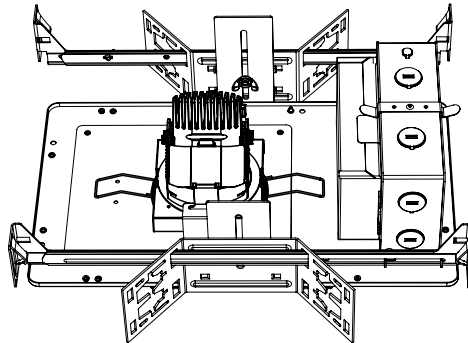
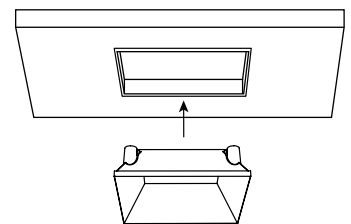

Figure C1



Step 1

Pull power wire through ceiling opening and connect to luminaire with quick connector (Figs. A & A1). Squeeze tension springs and push the light engine into the ceiling opening.

For square light engine, orient clips at 90° to notched tabs inside frame as shown in Figs. B & B1.

Note: for wallwash trim installation, ensure proper orientation towards wall before installing light engine.

Step 2

Secure light engine in frame as shown in top view (Figs. B & B1). Note orientation of square light engine clips at 90° to notched tabs inside frame.

Step 3

Install trims (Figs. C & C1).